

Migration Solutions

SLC 500 to CompactLogix 5380 and 5069 Compact I/O

Overview

In today's economy it is necessary to have migration solutions that help you to achieve increased productivity and lessen your risk of maintaining your legacy equipment. You need to work with a supplier that has the product, service, and industry knowledge to partner with you on an upgrade strategy that will help you maximize your competitive advantage.

Rockwell Automation® and its partners will work with you to outline a plan that fits your application needs and long-term goals. We can help you migrate all at once or in phases, at the pace that is comfortable for you and fits your budget.

With your goals in mind, Rockwell Automation has developed a migration strategy that will allow you to quickly and easily migrate from SLC-based control to Logix-based control and Integrated Architecture, while maintaining the existing field wiring. This approach will:

- Lower conversion time and labor costs
- Reduce risk by preserving existing field wiring connections
- Lower engineering costs
- Minimize production downtime



Simplifying SLC™ Migrations

- Minimizes risk and reduces labor time
 - convert I/O without disturbing field wiring connections
 - code conversion tools reduce time to rewrite controller program
- Improves migration and planning using Integrated Architecture Builder tool
- Supports various network topologies with the proven technology of EtherNet/IP

New Control System Benefits

- Increased flexibility with new open architecture
- Reduced development time and costs through re-use of engineering practices
- Maximized returns on existing assets through improved control and monitoring
- Increased access to plant and production information
- One programming environment for discrete, motion, process, drive, batch, and safety control

Choosing a Partner for your Project

When planning your migration, there are several resources available to help you develop a proactive lifecycle plan:

Migration Services from Rockwell Automation

Reduce lifecycle risks before, during and after the migration process with migration services that are tailored to your specific needs. Our modernization services and support are available to help you realize the benefits of CompactLogix System and a modern control architecture. Our factory-trained Field Service Professionals are experienced and prepared to provide onsite assessments, migration planning services, start-up and commissioning of your modernized control architecture. From project management to start-up, we will help define and implement an effective modernization strategy for your facility that goes beyond simply addressing your legacy equipment to truly optimizing your operation.

Recognized System Integrator or Solution Provider

Our **PartnerNetwork™** provides an integrated team of engineering specialists and suppliers that are leaders in the automation and manufacturing industry who have experience delivering products or services that are designed to work with Rockwell Automation® solutions.

Do It Yourself

If you prefer to migrate from SLC-based control system and 1746 I/O to CompactLogix system without assistance, Rockwell Automation provides a number of tools free of charge to help you plan and migrate with as little disruption as possible.

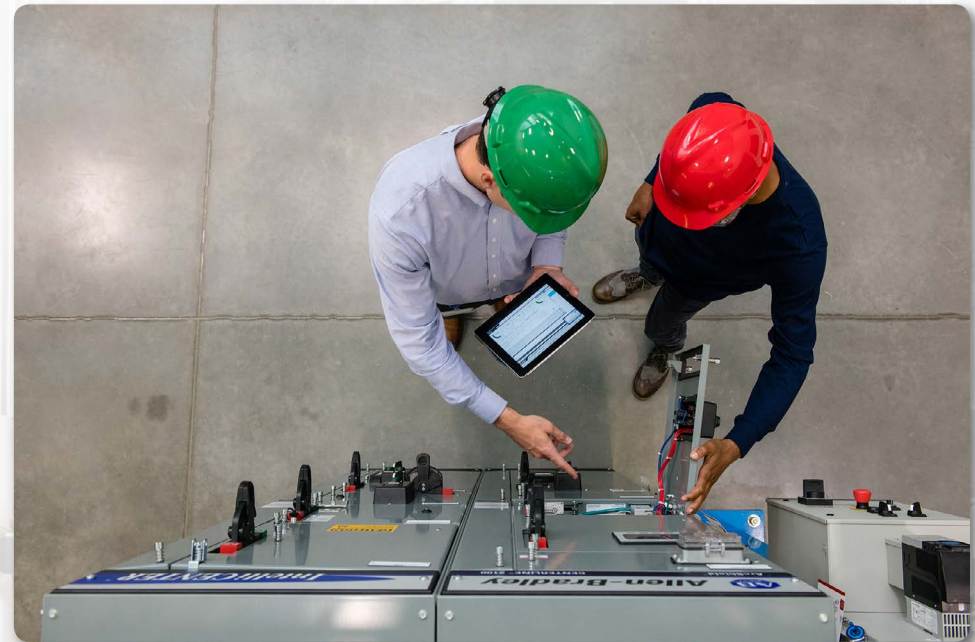

Tools to Plan and Execute your Migration

Rockwell Automation provides migration tools for hardware selection, code conversion and hardware conversion that practically eliminate the need to modify any field device wiring. All tools are available regardless of who performs the migration: Rockwell Automation, System Integrator, or Do It Yourself

Product Lifecycle Status

The online Product Lifecycle Status tool can help you determine the lifecycle of your existing equipment and identify the most contemporary Rockwell Automation products, bringing you advancements in performance, flexibility and security. Having this knowledge makes it easier to plan and manage the transition from legacy or obsolete equipment to leading-edge technologies.

Installed Base Evaluation

An Installed Base Evaluation provides a thorough analysis of your critical plant assets and their condition. This site-delivered service provides detailed reports by site, area, line, machine and panel.

Integrated Architecture Builder

The Integrated Architecture Builder (IAB) is a graphical, user-friendly software tool that allows you to automatically define and configure a contemporary CompactLogix-based architecture including a detailed bill of materials based on your current SLC-based control system.

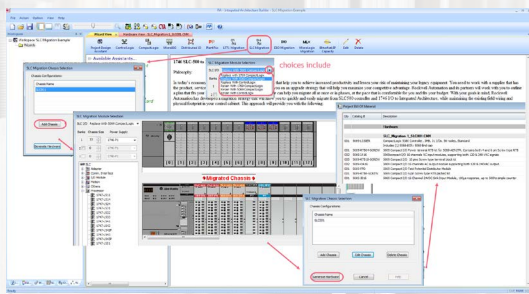

Popular Configuration Drawings for CompactLogix 5380

Use these system configuration the following system drawings as examples of how to build a scalable integrated architecture for your industrial application and understand the basic performance, capacity, and configurations the controllers can use.

ProposalWorks Proposal Builder

This tool helps you create bill of materials, RFQs, and proposals for your automation projects directly from your computer. The tool has 1,500 wizards and an easy-to-use search capability to find the right products to meet your application requirements.

RSLogix 5000 or Studio 5000 Project Migrator

The Project Migrator tool allows you to save time and engineering resources when converting your SLC 500 application code. After exporting your RSLogix 500 project file, you can use the using the embedded conversion utilities to import your code into RSLogix 5000 or Studio 5000 software.

Network Adaptor Module

The 1747-AENTR Ethernet adaptor module enables communication and data transfer between a CompactLogix controller and remote 1746 I/O via ethernet communications. It can be used to upgrade an existing SLC™ system to a CompactLogix system. The advantages of using the 1747-AENTR module in a phased modernization include allowing the existing Remote I/O network to remain in place and allows the new application to be tested before switch over and to switch back to the old application in minutes.



Controller and I/O Wiring Conversion Systems (Coming in 2019)

I/O Conversion Modules provide a fast and efficient method for converting from legacy I/O to contemporary I/O. The I/O conversion is accomplished without removing any field wires from the existing 1746 Swing Arm, virtually eliminating the risk of wiring errors. The existing 1746 Swing Arms fit directly onto the edge connector of the Conversion Modules.

Getting Started

With industry knowledge and worldwide services support, Rockwell Automation will partner with you to ensure a smooth transition from your SLC controllers to the flexible, scalable Integrated Architecture.

STEP 1

Document your Current System Layout and Define your Future System Requirements

Begin planning your migration by documenting your existing system as a reference point. This will enable you to consider the available options and find a solution that best meets your existing and future requirements.

Tools: [Installed Base Evaluation](#)

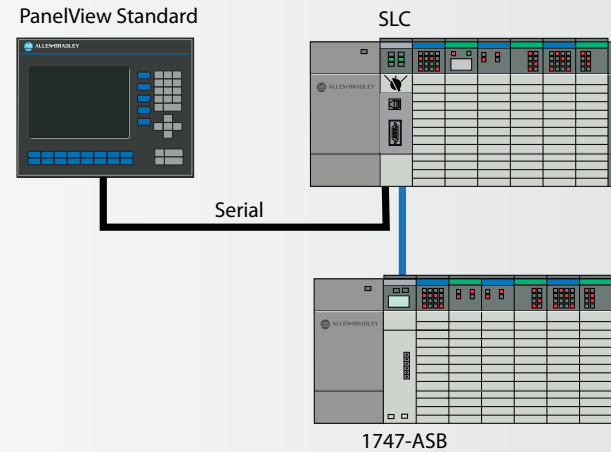

STEP 2

Plan your Migration

Once you have planned your overall migration approach, let Integrated Architecture Builder (IAB) help plan the details. The SLC migration wizard embedded in IAB will step you through the system configuration process, allowing you to make the decisions on which components you prefer to keep and reuse and which components you prefer to replace. If you choose to reuse the SLC I/O, IAB will verify module support and power supply loading and help you layout the new EtherNet/IP network.

Tools: [Integrated Architecture Builder \(IAB\)](#), [Popular Configuration Drawings](#)

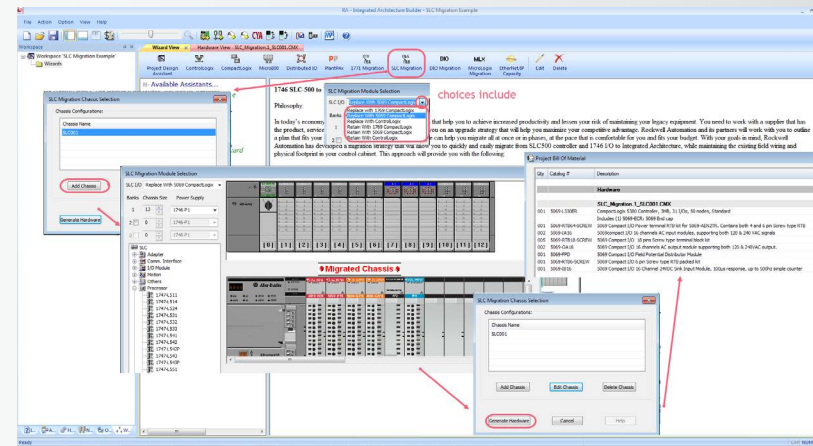

Moving Forward: Executing Your Project

Whether you choose to migrate all at once or in phases, we have the tools and experience to guide you through the transition. Our approach to modular automation coupled with backward compatibility allows you to maintain productivity as you upgrade portions of your automation system. Migrate in phases at a pace that's right for you.

PHASE 1

Application Code Conversion

Save time and engineering resources when converting your SLC 500 application code by using the embedded conversion utilities in either RSLogix 5000 or Studio 5000 software. And, converting your PanelView Standard project to PanelView Plus is as simple as importing the existing project into FactoryTalk View Studio.

Tools: RSLogix 5000 and Studio 5000 software, FactoryTalk View Studio Software

Benefits (application code):

- Convert 80-100% of code using automated code conversion
- Take advantage of powerful constructs and features that you can leverage to improve the application

Benefits (HMI application):

- 80% of the time no further modification is required for HMI application
- Utility generates conversion log identifying features not supported by new hardware selected
- Option to take advantage of enhanced features and graphics
- Better integration with controllers



PHASE 2

Replace the SLC Processor and/or Adaptor Modules

Mount and wire the CompactLogix™ system and replace the SLC first slot modules (SLC processor or communication adaptor module) with the SLC Ethernet adaptor (1747-AENTR). Utilizing this module allows you to retain your existing SLC I/O and preserve existing field wiring, while allowing your SLC I/O chassis to be controlled from your new CompactLogix controller. This approach simplifies the migrations process, reduces risks associated with rewiring the I/O, and saves valuable time allowing you to quickly get your application into production.

Tools: 1747-AENTR Ethernet adaptor, CompactLogix User Manual

Benefits:

- Maintain existing field wiring
- Minimize commissioning time and effort
- Ability to return to SLC control, if needed

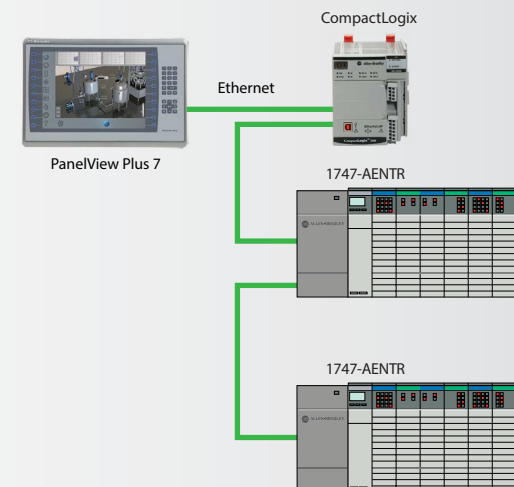

Moving Forward: Executing Your Project

PHASE 3

Replace other System Components

Because Rockwell Automation is a comprehensive supplier, we can help with other products and services. If your control system has legacy or competitive variable speed drives, motion control, sensors or motor control centers we can discuss how we can help migrate those products as well. But it doesn't stop there. We have a worldwide service group that can do the migration work, assist and train operators or provide the maintenance services once it's complete. We can also review your network needs and review asset management for your entire facility.

Tools: Popular Configuration Drawings for CompactLogix 5380

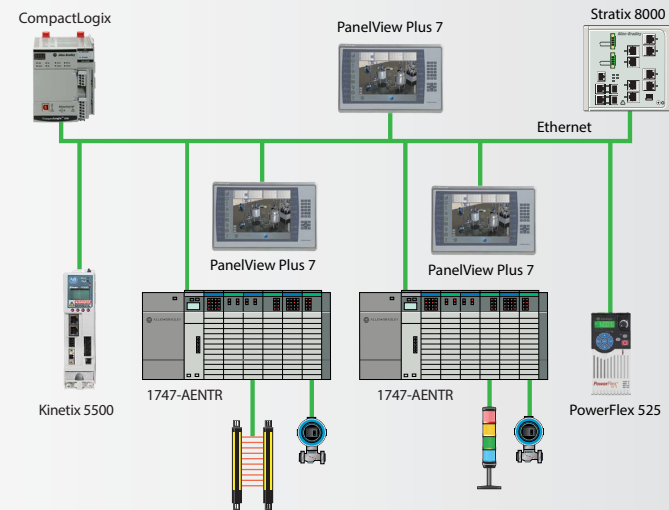

PHASE 4

I/O Replacement (FUTURE STATE)

In the final phase of the migration process, the I/O Wiring Conversion System is used to replace the 1746 I/O with the CompactLogix I/O. Because I/O replacement represents a large investment, we provide an approach that's right for your schedule and budget. The I/O Wiring Conversion System provides a method to connect the existing 1746 I/O wiring to the 5069 I/O modules without disturbing the field wiring connections, dramatically reducing labor time and eliminating the potential for downtime that could result from wiring mistakes during the migration. Planning your migration is more manageable as I/O can be swapped one rack at a time or all at once based on your schedule and budget. In either case, you can run both new and old I/O networks simultaneously. Additionally, I/O cross reference documentation assures correctness and provides historical back-up for future troubleshooting or diagnostics.

Tools: I/O Wiring Conversion System (Coming in 2019), ProposalWorks Selection Software

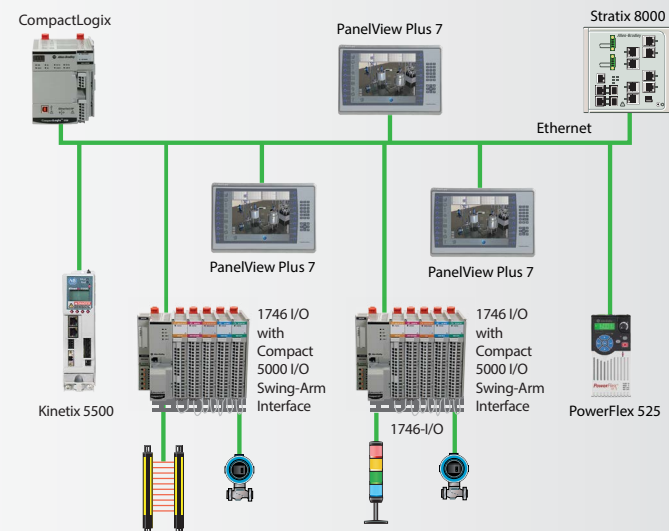

Complete Conversion Services

In any phase of your conversion project, Rockwell Automation can provide you with technical, industry and project management expertise to help make a migration project easier. We will help you design a plan to account for your short- and long-term goals. You will be assigned a primary engineer who will be responsible for coordinating and scheduling implementation activities and resources, and who will also be the primary communications contact.

On-site Assessment

Using standardized checklists and processes, a job site visit will be performed to confirm the project scope, validate risks, review testing and acceptance criteria, and gather the required information and software to convert existing screens and configurations.

You will receive:

- Completed risk assessment form
- Bill of materials
- Conversion acceptance criteria
- Project schedule and timeline
- Required information sent to conversion engineer team

To request a migration quote, please contact your local authorized Allen-Bradley distributor or Rockwell Automation sales office.

If you need additional help, Rockwell Automation can provide: Application level phone support during the start-up and debugging phase of the project

Consultation on system re-engineering, operator interface, architecture and communication strategies, training, and on-site start-up is available through our local Rockwell Automation office.

Application Conversion Engineering Services

Using custom-developed proprietary software applications designed to convert existing configurations, our engineers will complete and test the screen conversion process and any required PLC code changes necessary.

We can help you:

- Decrease turn-around time
- Save money
- Minimize errors that can occur in a manual conversion

Deliverables include:

- The existing console and configurations converted to the appropriate Logix controller and FactoryTalk products
- Conversion of the documentation database
- Correct and convert any instruction and/or addressing errors to the new processor family
- Multilingual database conversion offered

Start-up and Acceptance

Prior to installation, comprehensive functional testing will be performed including pre-loading of all applicable software and firmware. Once installation is complete, our engineer, working closely with your plant staff, will conduct an operational compliance review. Comprehensive system documentation will be provided upon project acceptance.

Deliverables include:

- Pre-operational checklist
- Operational test performed and validated by customer
- Customer acceptance
- Necessary documentation, including product sheets and software files

Allen-Bradley, CompactLogix, RSLogix, SLC 500, and Studio 5000 are trademarks of Rockwell Automation, Inc. Trademarks not belonging to Rockwell Automation are property of their respective companies.

www.rockwellautomation.com

Power, Control and Information Solutions Headquarters

Americas: Rockwell Automation, 1201 South Second Street, Milwaukee, WI 53204-2496 USA, Tel: (1) 414.382.2000, Fax: (1) 414.382.4444

Europe/Middle East/Africa: Rockwell Automation NV, Pegasus Park, De Kleetlaan 12a, 1831 Diegem, Belgium, Tel: (32) 2 663 0600, Fax: (32) 2 663 0640

Asia Pacific: Rockwell Automation, Level 14, Core F, Cyberport 3, 100 Cyberport Road, Hong Kong, Tel: (852) 2887 4788, Fax: (852) 2508 1846